

REF. NO.	PART NO.	PART NAME	QTY.
1.	E09-8000	TAIL BOOM ASSEMBLY.....	1
2.	E18-3000	TAIL ROTOR GEARBOX ASS'Y. FRONT.....	1
3.	E18-3600	DRAIN PLUG/CHIP DETECTOR.....	2
4.	E18-3610	OIL FILLER PLUG.....	2
5.	E00-2411	BOLT AN4-20A (1/4 X 2).....	1
	E00-3402	NUT 1/4-28 FIBERLOCK AN365-428A.....	1
	E00-4401	WASHER 1/4 REGULAR AN960-416.....	2
6.	E18-4500	PULLEY, FRONT GEARBOX.....	1
	E18-4520	BELT, SECONDARY TO GEARBOX.....	1
7.	E00-9313	SET SCREW 1/4-28 X 1-1/2.....	8
	E00-3402	NUT 1/4-28 FIBERLOCK AN365-428A.....	8
	E00-4401	WASHER 1/4 REGULAR AN960-416.....	8
8.	E18-4610	UNIVERSAL JOINT.....	2
9.	E00-2407	BOLT AN4-13A(1/4 X 1-3/8).....	8
	E00-3402	NUT 1/4-28 FIBERLOCK AN365-428A.....	8
	E00-4401	WASHER 1/4 REGULAR AN960-416.....	16
10.	E18-4100	DRIVE SHAFT WELDMENT, FRONT.....	1
11.	E18-4650	GREASE ZERK.....	2
12.	E00-2403	BOLT AN4-7A (1/2 X 7/8).....	6
	E00-3402	NUT 1/4-28 FIBERLOCK AN365-428A.....	6
	E00-4401	WASHER 1/4 REGULAR AN960-416.....	12
13.	E18-4200	SPLINED SHAFT WELDMENT.....	2
14.	E18-4300	DRIVE SHAFT, MIDDLE.....	1
15.	E18-4660	BEARING, T/R DRIVE SHAFT.....	2
	E18-4670	FLANGE, T/R SHAFT BEARING.....	4
16.	E18-4400	DRIVE SHAFT WELDMENT, REAR.....	1
17.	E18-3010	TAIL ROTOR GEARBOX ASS'Y. REAR.....	1
18.	E09-3120	TUNNEL INSPECTION DOORS.....	3
19.	E09-3221	TAIL BOOM ATTACH. BRACKET, UPPER.....	2
20.	E09-3231	TAIL BOOM ATTACH. BRACKET, LOWER.....	2
21.	E00-2308	BOLT AN3-15A (3/16 X 1-5/8).....	2
22.	E00-2307	BOLT AN3-13A (3/16 X 1-3/8).....	6
	E00-3301	NUT 3/16 FIBERLOCK AN365-1032A.....	8
	E00-4301	WASHER 3/16 REGULAR AN960-10.....	8
23.	E00-8000	DZUS BUTTON REG LENGTH AJ5-35.....	8
	E00-8010	DZUS GROMMET GA5-312.....	8
	E00-8020	DZUS SPRING SSA-225.....	8
	E00-6205	RIVET 1/8 X 1/4 ALUM CSK POP.....	16
24.	E00-1200	SCREW 8-32X 7/16 PHILLIPS HEAD.....	8
	E00-7000	NUT PLATE NAS680A-08 8-32.....	8
	E00-6200	RIVET 3/32 X 1/8 ALUM CSK POP.....	16
25.	E09-3130	TUNNEL INSPECTION DOOR.....	1

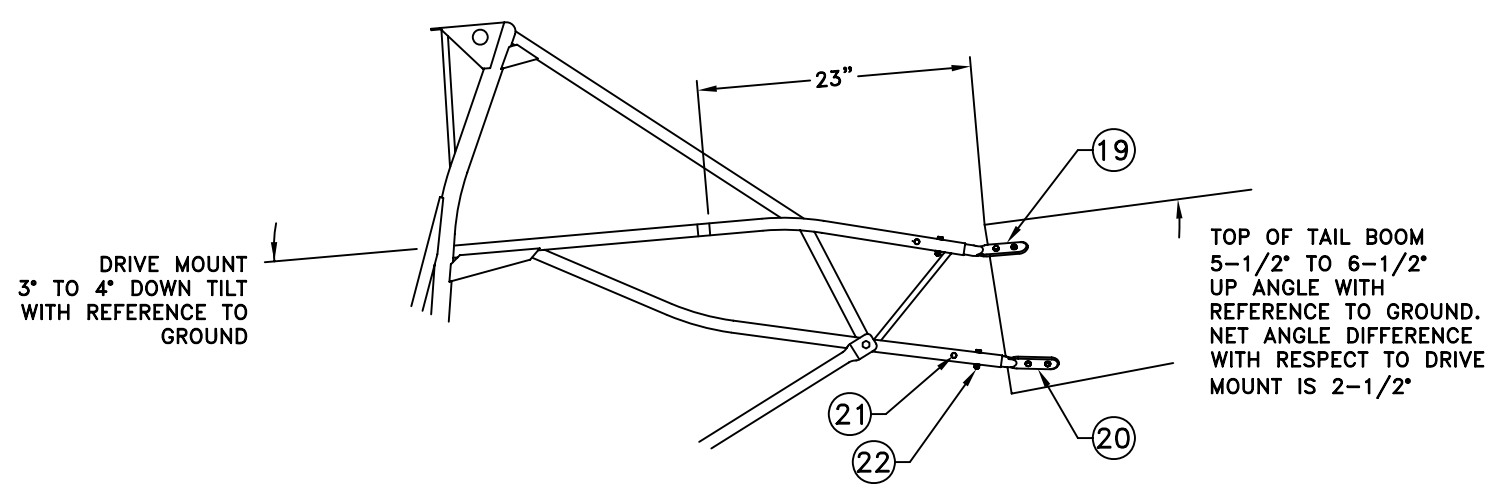

ROTORWAY INTERNATIONAL CHANDLER, ARIZONA			
SCALE: NONE	APPROVED BY:	DRAWN BY: WAR	
DATE: 1-07-08		REVISED: 5-12-10	
TAIL BOOM ASSEMBLY			
MODEL: A600 TALON	DRAWING NUMBER:		E09-2000